



# 03.W129 Dual Speed Alternating Headlight Flasher INSTRUCTIONS

**Attention Installers: This flasher must be installed by a qualified technician.**

It is the final responsibility of the installer of headlight flashers to determine their compatibility with the vehicle make and model in which they will be installed. Incorrect wiring of headlight flashers could result in costly problems or even permanent damage to the vehicle's computer module.

**NOTE:** Do not install any **SHO-ME**® headlight flashers on 2000 model year or newer Dodge Durangos or Dodge Dakotas. Our flashers are **not** compatible with these vehicles and may lead to the failure of their computer systems.

**CAUTION!**

This flasher **MUST** be wired through a circuit controlled by the ignition switch  
**DO NOT** wire directly to the battery.

This flasher is designed to flash high beam headlights of emergency vehicles. Also provided are several options for customizing the installation of the flasher.

**OPTION 1:** If the flasher is to be used to flash headlights on a vehicle, the wire marked high beam override should be connected to the wire coming from the dimmer switch.

**OPTION 2:** If it is not legal in your area to flash headlights at night, connect the wire marked "night cutoff" to the hot wire going to the parking lights of the vehicle. This will prevent flashing the headlights at night. This will not interfere with normal high beam operation during day or night.

**OPTION 3:** If it is desired to have a faster flash rate, connect the wire marked "high speed" to positive. This wire will not turn on the flasher, but will increase the flash rate any time the flasher is operating. This wire requires less than .05 amps to operate, thus it may be connected to the control of a siren and will increase the flash rate of the flasher any time the siren and flasher are activated.

**OPTION 4:** The wire marked "horn" may be connected to the positive wire going to the horn of the vehicle. If this is done, the high beam headlights will both come on any time the horn is honked. This provides visual as well as audio warning for the vehicle, even if the flasher is not activated.

When selecting a location to mount the flasher, keep in mind that the life of any electronic device is directly dependent on the temperature in which it is operated - the cooler the unit, the longer the life. Select a mounting location that is away from sources of extreme heat.

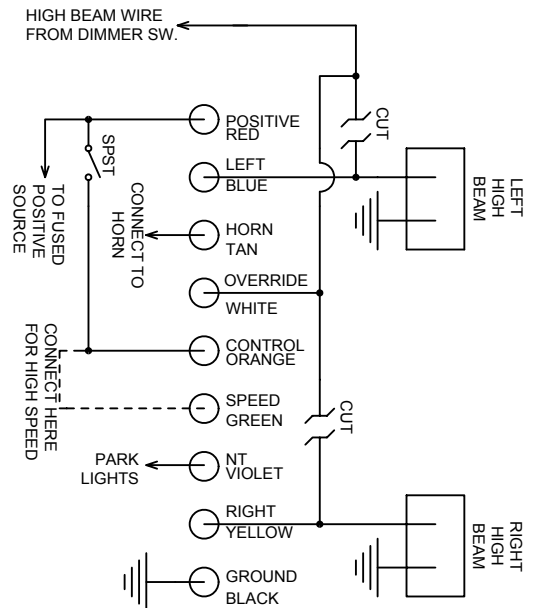

**PRODUCTS COMPANY** 804 East Hwy 248 Cassville, MO 65625  
U.S. and Canada Toll Free Numbers Phone: 800-641-4098 FAX: 800-526-1240  
E-mail: sales@able2products.com WEB: www.able2products.com