



03.W140
Bi-Directional Headlight Flasher
INSTRUCTIONS

Attention Installers: This flasher must be installed by a qualified technician.

It is the final responsibility of the installer of headlight flashers to determine their compatibility with the vehicle make and model in which they will be installed. Incorrect wiring of headlight flashers could result in costly problems or even permanent damage to the vehicle's computer module.

NOTE: Do not install any **SHO-ME**® headlight flashers on 2000 model year or newer Dodge Durangos or Dodge Dakotas. Our flashers are **not** compatible with these vehicles and may lead to the failure of their computer systems.

CAUTION!

This flasher **MUST** be wired through a circuit controlled by the ignition switch
DO NOT wire directly to the battery.

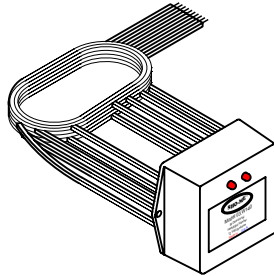

General Information:

This Random headlight flasher with High Beam Override and (optional) Nighttime Cutoff, can be used on vehicles with Positive-Side switching or Ground-Side switching.

Ground-Side Switching:

Means that the headlight "common" wire is connected to +12 volts, and the headlight is activated when the dimmer switch connects ground (0 volts) to the high or low beam.

Positive-Side Switching:

Means that the headlight "common" wire is connected to (0 volts) and the headlight is activated when the dimmer switch connects (+12v) to the high or low beam.

Nighttime Cut Off:

If it is not legal in your area to flash headlights at night, for **Positive-Side Switching** connect the BROWN wire to the parking light and the WHITE/BROWN wire with the ORANGE wire. For **Ground-Side Switching** connect the BROWN wire to ground and connect the WHITE/BROWN to the parking lights. This will prevent the flashing the headlights at night. This will not interfere with normal high beam operation during day or night.

NOTE: It is essential to contact the vehicle manufacturer to determine which methods are being used. It is the responsibility of the end user to confirm the warranty conditions with the vehicle manufacturer. The installation of a headlight flasher system requires a modification to the standard headlight wiring harness. This modification may affect the warranty of your vehicle.

Installation:

Before installation of this flasher, disengage the battery from electrical system. When selecting a location to mount the flasher, keep in mind that the life of any electronic device is directly dependent on the temperature in which it is operated - the cooler the unit, the longer the life. Select a mounting location that is away from sources of extreme heat.



PRODUCTS COMPANY 804 East Hwy 248 Cassville, MO 65625
U.S. and Canada Toll Free Numbers Phone: 800-641-4098 FAX: 800-526-1240
E-mail: sales@able2products.com WEB: www.able2products.com

There are 4 flash rates for the **03.W140**. Two jumper wires, WHITE/RED and WHITE/VIOLET, determine these rates. The following table defines the available flash rates.

WHITE/VIOLET	WHITE/RED	FLASH RATE
Intact	Intact	Random Flash
Cut	Intact	90 Flashes Per Minute / Alternating
Intact	Cut	90 Flasher Per Minute / Simultaneous
Cut	Cut	Double Alternating / Simultaneous

Random Flash:

- 90 flashes per minute
- 120 flashes per minute alternating
- 90 flashes per minute simultaneous
- Double flash alternating
- Double flash simultaneous
- Variable speed alternating

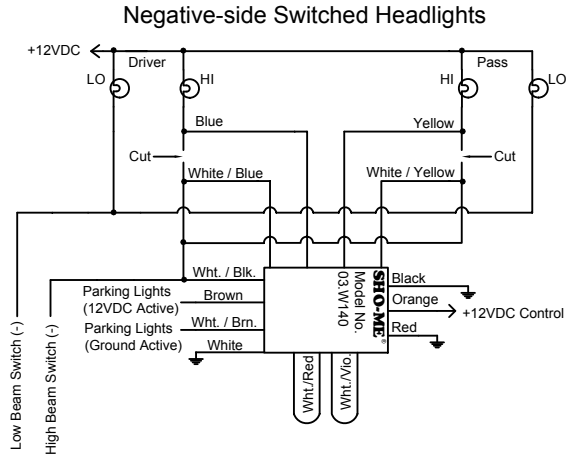
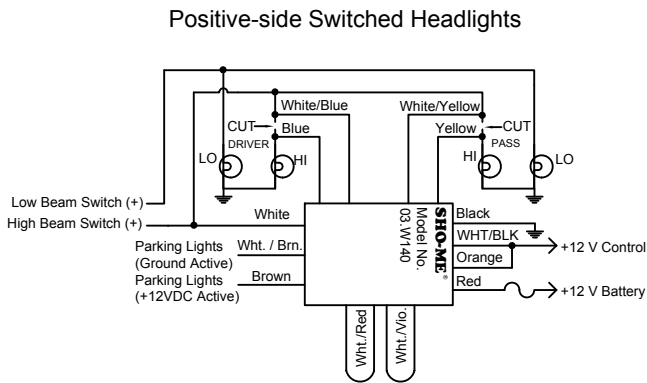

LIMITED WARRANTY

Able 2 Products Company warrants each new product (except bulbs, strobe tubes, strobe power supplies and LED Products) to be free from defects in material and workmanship for a period of two years from the date of purchase. During this warranty period, the obligation of Able 2 is limited to repairing or replacing, as Able 2 may elect, any part or parts, which after examination by Able 2 are determined to be defective, when they are delivered pre-paid. This limited warranty does not cover travel expense, the cost of specialized equipment for gaining access to the product, or labor charges for the removal and re-installation of the product.

Able 2 Products Company shall not be liable for incidental or consequential damages, including but not limited to : Loss of use of vehicle, Rental of substitute vehicle, Loss of time, Loss of work, Inconvenience, Transportation expenses, Telephone, Lodging, Loss of revenue, Loss of and /or damage to personal property for or arising out of breach of any express or implied warranty of its products.

Use of lamp or other electrical load of a wattage higher than installed or recommended by the factory, or use of inappropriate or inadequate wiring or circuit protection causes this limited warranty to become void. Able 2 Products Company will in no way be liable for any loss of profits or any indirect or consequential damages arising out of any such defect in material and workmanship whether loss is due to negligence or breach of warranty. This limited warranty does not apply to shipping damage, accident, alteration, tampering, misuse or abuse and unauthorized service.

This limited warranty is expressly in lieu of all other express or implied warranties, including the implied warranty of merchantability and the implied warranty of fitness for a particular purpose, and of all other obligations or liabilities on the part of Able 2 Products Company. There are no warranties, unless expressed in authorized Able 2 literature, which extend beyond the description of the face hereof. No dealer, distributor, employee, or representative of the company is authorized to change this warranty in any way or to grant any other warranty.

WARRANTIES:

All LED Products	5 Years
T Model & Potted Strobe Power Supplies	2 Years
All Other Strobe Power Supplies	5 Years
All Other Products EXCEPT Bulbs	2 Years (under normal use)
Strobe Tubes	1 Year (under normal use)

NOTE: Halogen and Incandescent Bulbs are not covered by warranty.

PRODUCT RETURNS

If a product must be returned, contact our factory by calling 1-800-641-4098 to obtain a Return Authorization Number (RA) before you ship the product. Write the RA Number clearly on the package and return it to Able 2 Products Company, P.O. Box 543, 804 E. Hwy. 248, Cassville, MO 65625-0543. A packing slip should be included with all shipments listing the sender's name, address, daytime phone number and description of defect. Your product will be put in first-class operating condition or replaced with a new part, and returned pre-paid.